



■ 特性

- 国际通用全范围交流输入
- 内置 EMI 滤波器
- 具有过流及短路保护
- 过压/过温/过负载保护
- 100%负载老化
- 冷却方式：自冷
- LED 电源指示灯
- 高效率，长寿命和高信赖度
- 可根据用户选型定制

■ Characteristic

- International Universal AC input/ Full range
- Built-in EMI filter
- Short circuit/Over load Protections
- Over voltage& temperature & Load Protections
- 100% full load burn-in test
- Cooling: Self-cooling
- LED indicator for power
- High efficiency, long life and high reliability
- Can be customized according to user selection

电气规格 SPECIFICATION

型号 MODEL		AD-S05100AA	AD-S0950AA	AD-S1240AA	AD-S1532AA	AD-S2420AA	AD-S4810AA
输出 Output	直流电压 DC Voltage	5V	9V	12V	15V	24V	48V
	额定电流 Rated Current	10A	5A	4A	3.2A	2A	1A
	电流范围 Current Range	0~10A	0~5A	0~4A	0~3.2A	0~2A	0~1A
	额定功率 Rated Power	50W	45W	48W	48W	48W	48W
	波纹与噪声最大 (备注2) Ripple & Noise Max (Note2)	120mVp-p	120mVp-p	120mVp-p	120mVp-p	120mVp-p	120mVp-p
	电压调整范围 Voltage Adj. Range	±10%	±10%	±10%	±10%	±10%	±10%
	电压精度 (备注3) Voltage Tolerance (Note3)	±7%	±7%	±6%	±5%	±5%	±5%
	线性调整率 (备注4) Line Regulation (Note4)	±0.5%	±0.5%	±1%	±1%	±1%	±1%
	负载调整率 (备注5) Load Regulation (Note5)	±2.0%	±1.0%	±1.0%	±1.0%	±1.0%	±1.0%
	启动、上升时间 Setup、Rise Time	1000ms, 30ms/220Vac (满载时 Full load)					
保持时间 (Typ.) Hold up time (Typ.)	100ms/220Vac (满载时 Full load)						
输入 Input	电压范围 Voltage Range	100~240Vac					
	频率范围 Frequency Range	50/60Hz					
	效率 (Typ.) Efficiency (Typ.)	80%	80%	85%	85%	80%	80%
	交流电流 (Typ.) Ac Current (Typ.)	0.8A/220Vac					
	浪涌电流 (Typ.) Inrush Current (Typ.)	冷启动 Cold Start: 50A/220Vac					
	漏电流 (Typ.) Leakage Current (Typ.)	3mA					
保护 Protection	过载保护 Over load protection	110%~135% 保护模式：打嗝模式，负载异常条件移除后可自动恢复 Protection type: Hiccup mode, recovers automatically after fault condition is removed					
	过压保护 Over Voltage protection	115%~150% 保护模式：打嗝模式，过压异常条件移除后可自动恢复 Protection type: Hiccup mode, recovers automatically after fault condition is removed					
	过温保护 Over-temperature protection	保护模式：晶体内部接点温度超过 140℃，关闭输出，当温度恢复正常可自动恢复 Protected Mode: crystal internal contact temperature exceeds 140℃, turn off the output, when the temperature returns to normal automatic recovery					
环境 Environment	工作温度 Working Temp	-10℃~60℃ (请参照“减额曲线” Refer to "derating curve")					
	工作湿度 Working Humidity	20~90%RH, 无冷凝 non-condensing					
	储存温度、湿度 Storage Temp、Humidity	-30℃~75℃ 10~98%RH, 无冷凝 non-condensing					
	温度系数 Temp Coefficient	±0.03% /℃ (0~50℃) (+5V)					
	耐振荡 Vibration	10~500Hz, 5G 10分钟/周期, X、Y、Z 轴各 60分钟 10Min/1 cycle, period for 60min, each along X,Y,Z axes					
安规和电磁兼容 (备注7) Safety & EMC (Note 7)	安全规范备注6 Safety Standards Note 6	GB4943, EN60950					
	耐压 Withstand Voltage	I/P-O/P: 3KVAC I/P-FG: 1.5KVAC O/P-FG: 1.5KVAC					
	绝缘阻抗 Isolation Resistance	I/P-O/P I/P-FG O/P-FG: 100M Ohms/500VDC/25℃/70%RH					
	电磁兼容发射 EMI Conduction Radiation	符合 Compliance to :EN55022, EN61000-3-2, 3. FCC part15, GB9254 class B, GB17625.1					
	电磁兼容抗扰度 EMS Immunity	符合 Compliance to :EN61000-4-2, 3, 4, 5, 6, 8, 11, A 级轻工业标准 light industry level, criteria A					
其它 Others	MTBF	≥100000h.					
	尺寸 Dimension/包装 Packing	159*98*42mm (L*W*H) /0.4Kg; 100pcs/40Kg					
备注 Note	<p>1. 如未特别说明，所有规格参数均在输入为 220VAC、额定负载、25℃环境温度下进行测量。 All parameters NOT specially mentioned are measured at 220VAC input, rated load and 25℃ of ambient temperature.</p> <p>2. 波纹和噪声测量方法：使用一条 12" 双绞线，同时终端要并联 0.1uF 和 47uF 的电容，在 20MHZ 带宽下进行量测。 Ripple & noise are measured at 20MHZ of bandwidth by using a 12" twisted pair-wire terminated with a 0.1uF & 47uF parallel capacitor</p> <p>3. 精度：包含设定误差，线性调整率和负载调整率。 Tolerance: includes set up tolerance, line regulation and load regulation</p> <p>4. 线性调整率测量方法：在额定负载下，从低电压到高电压测试。 Line regulation is measured from low line to high line at rated load.</p> <p>5. 负载调整率测量方法：从 0% 到 100% 额定负载。 Load regulation measurement: from 0% to rated load of 100%</p> <p>6. 按照 GB4943.1 的要求，电源仅适用于海拔 2000 米以下地区和非热带气候条件下安全使用。 In accordance with the requirements of GB4943.1 power applies only to an altitude of 2000 meters in the following areas and non-tropical climate conditions for safe use</p> <p>7. 电源被视为系统内元件的一部分，需结合终端设备进行电磁兼容相关确认。 The power supply is considered part of the system components, to be with terminal equipment related to electromagnetic compatibility Relevant confirmation.</p>						

尺寸 Size

单位: mm

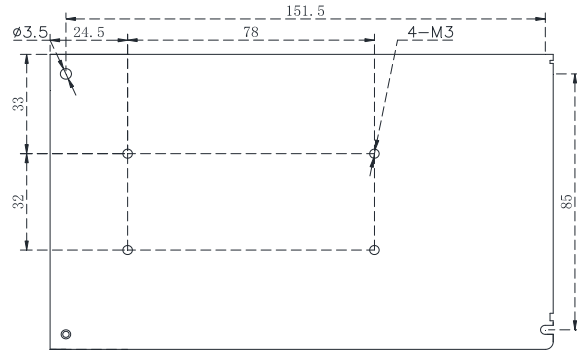
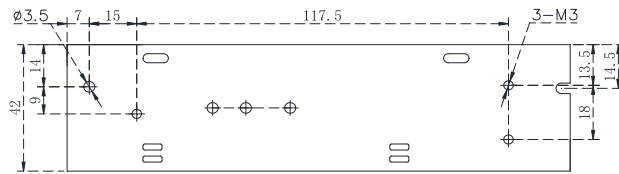
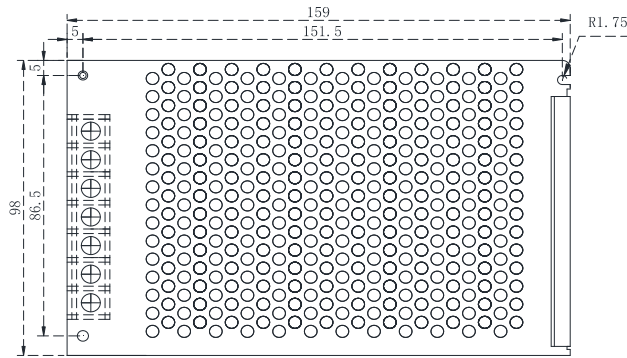

脚位 Pin No.	引进功能 Assignment
1	AC/L
2	AC/N
3	FG 地
4	DC/V-
5	DC/V-
6	DC/V+
7	DC/V+

方框图

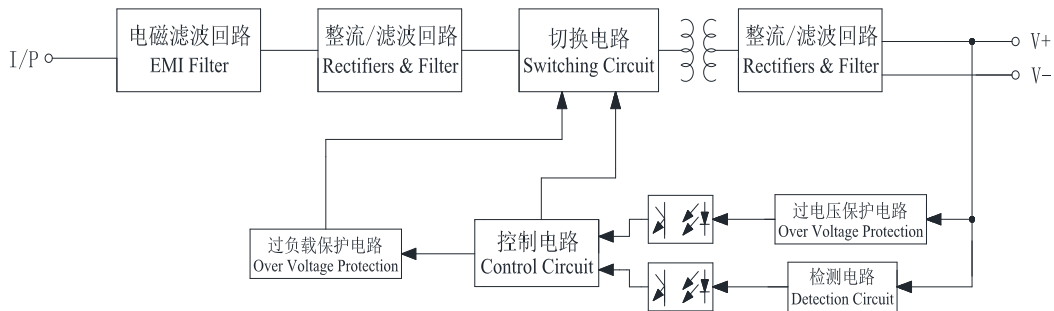

减额曲线

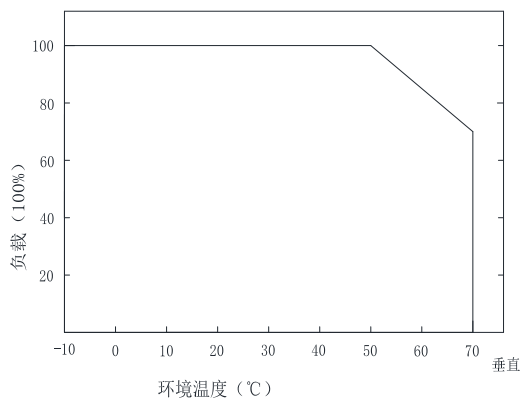

静态特性曲线

