



## ■ 特性

## ■ Characteristic

- 国际通用全范围交流输入
- 符合 EMC 电磁兼容标准
- 具有过流及短路保护
- 过压/过温/过负载保护
- 带 PFC 功率因数校正
- 全铝外壳散热可选择温控风冷
- LLC 双管谐振拓扑效率最高达 95%
- 最大输出电流 11A. 最大输出功率 260W. 电压可根据客户要求
- maximum current 11 a maximum power 260 w voltage can according to customer's requirements

## 电气规格 SPECIFICATOIN

型号 MODEL		PF-260-24	PF-260-48	PF-260-52
输出 Output	直流电压 DC Voltage	24V	48V	52V
	额定电流 Rated Current	10.8A	5.5A	5A
	电流范围 Current Range	0~10.8A	0~5.5A	0~5A
	额定功率 Rated Power	260W	260W	260W
	波纹与噪声最大 (备注2) Ripple & Noise Max (Note2)	240mVp-p	240mVp-p	240mVp-p
	电压精度 (备注3) Voltage Tolerance (Note 3)	±3%	±3%	±3%
	线性调整率 (备注4) Line Regulation (Note 4)	±1%	±1%	±1%
	负载调整率 (备注5) Load Regulation (Note 5)	±5%	±5%	±5%
	启动、上升时间 Setup、Rise Time	800ms, 50ms/220Vac (满载时 Full load)		
	保持时间 (Typ.) Hold up time (Typ.)	30ms/220Vac (满载时 Full load)		
输入 Input	电压范围 Voltage Range	100~264Vac		
	频率范围 Frequency Range	50/60Hz		
	效率 (Typ.) Efficiency (Typ.)	92%	93%	93%
	功率因数 (Typ.) The power factor (Typ.)	0.9>230VAC 0.95>110VAC (满载时 Full load)		
	交流电流 (Typ.) Ac Current (Typ.)	1.5A/230Vac 3A/115Vac		
	浪涌电流 (Typ.) Inrush Current (Typ.)	冷启动 Cold Start: 30A/220Vac		
	漏电流 (Typ.) Leakage Current (Typ.)	<1.5MA/240VAC		
保护 Protection	过载保护 Over load protection	110%~150% 保护模式: 打嗝模式, 负载异常条件移除后可自动恢复 Protection type: Hiccup mode, recovers automatically after fault condition is removed		
	过压保护 Over Voltage protection	115%~150% 保护模式: 打嗝模式, 过压异常条件移除后可自动恢复 Protection type: Hiccup mode, recovers automatically after fault condition is removed		
	过温保护 Over-temperature protection	保护模式: 晶体内部接点温度超过 140℃, 关闭输出, 当温度恢复正常可自动恢复 Protected Mode: crystal internal contact temperature exceeds 140 °C, turn off the output, when the temperature returns to normal automatic recovery		
环境 Environment	工作温度 Working Temp	-40℃~70℃ (请参照“减额曲线” Refer to “derating curve”)		
	工作湿度 Working Humidity	20~90%RH, 无冷凝 non-condensing		
	储存温度、湿度 Storage Temp、Humidity	-30℃~75℃ 10~98%RH, 无冷凝 non-condensing		
	温度系数 Temp Coefficient	±0.03% /℃ (0~50℃) (+5V)		
	耐振荡 Vibration	10~500Hz, 5G 10分钟/周期, X、Y、Z 轴各 60分钟 10Min/1 cycle, period for 60min, each along X, Y, Z axes		
安规和电磁兼容 (备注7) Safety & EMC (Note 7)	安全规范备注6 Safety Standards Note 6	GB4943, EN60950		
	耐压 Withstand Voltage	I/P-O/P: 3.0KVAC I/P-FG: 1.5KVAC O/P-FG: 0.5KVAC		
	绝缘阻抗 Isolation Resistance	I/P-O/P I/P-FG O/P-FG: 100M Ohms/500VDC/25℃/70%RH		
	电磁兼容发射 EMI Conduction Radiation	符合 Compliance to :EN55022, EN61000-3-2, 3, FCC part15, GB9254 class B, GB17625.1		
其它 Others	电磁兼容抗扰度 EMS Immunity	符合 Compliance to :EN61000-4-2, 3, 4, 5, 6, 8, 11, A 级轻工业标准 light industry level, criteria A		
	MTBF	≥100000h.		
其它 Others	尺寸 Dimension/包装 Packing	147*82*35mm (L*W*H) /0.6KG; 20pcs/12Kg		
	备注 Note	<p>1. 如未特别说明, 所有规格参数均在输入为 220VAC、额定负载、25℃环境温度下进行测量。 All parameters NOT specially mentioned are measured at 220VAC input, rated load and 25℃ of ambient temperature.</p> <p>2. 波纹和噪声测量方法: 使用一条 12”双绞线, 同时终端要并联 0.1uF 和 47uF 的电容, 在 20MHZ 带宽下进行量测。 Ripple &amp; noise are measured at 20MHz of bandwidth by using a 12” twisted pair-wire terminated with a 0.1uf &amp; 47uf parallel capacitor</p> <p>3. 精度: 包含设定误差, 线性调整率和负载调整率。 Tolerance: includes set up tolerance, line regulation and load regulation</p> <p>4. 线性调整率测量方法: 在额定负载下, 从低电压到高电压测试。 Line regulation is measured from low line to high line at rated load.</p> <p>5. 负载调整率测量方法: 从 0%到 100%额定负载。 Load regulation measurement: from 0% to rated load of 100%</p> <p>6. 按照 GB4943.1 的要求, 电源仅适用于海拔 2000 米以下地区和非热带气候条件下安全使用。 According to the requirements of GB4943.1, power is only elevation 2000 meters area and the safe use of the tropical climate conditions.</p> <p>7. 电源被视为系统内元件的一部分, 需结合终端设备进行电磁兼容相关确认。 The power supply is considered part of the system components, to be with terminal equipment related to electromagnetic compatibility Relevant confirmation.</p>		

尺寸 Size

单位: mm

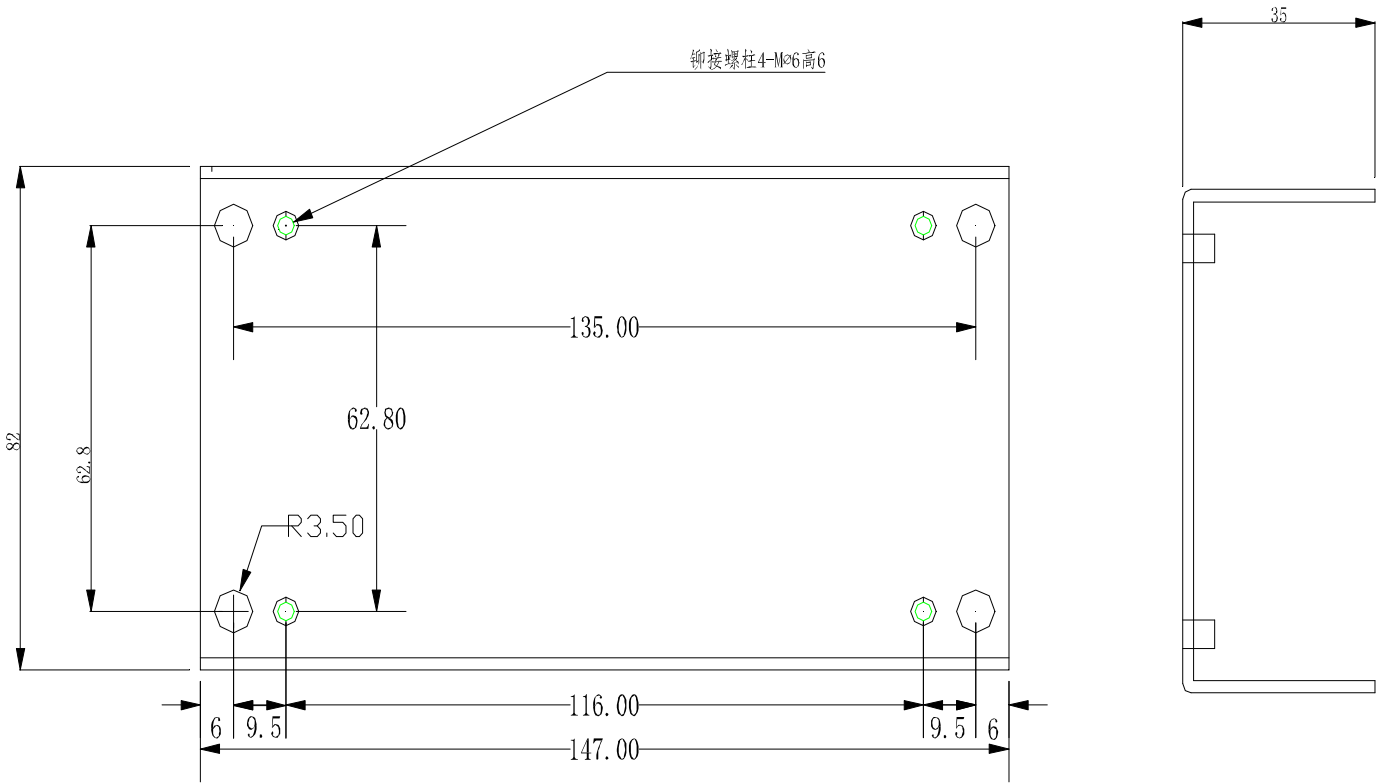

方框图 Block diagram

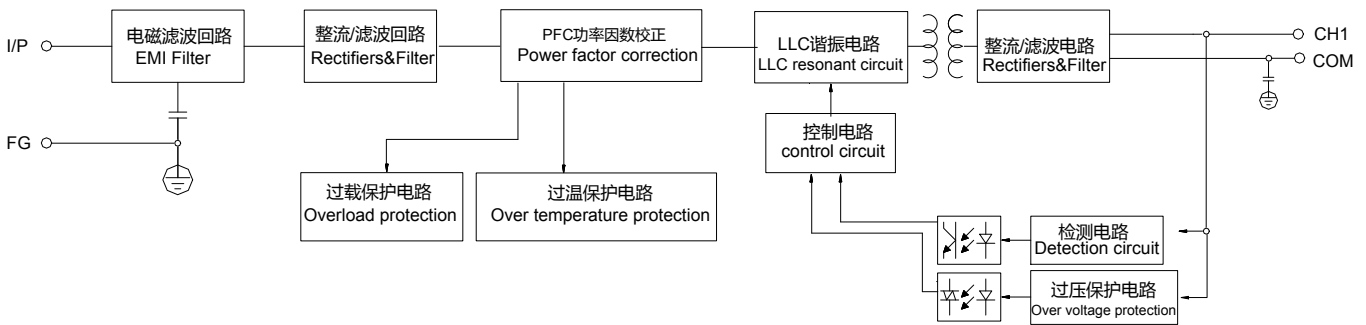

减额曲线 Deduction curve

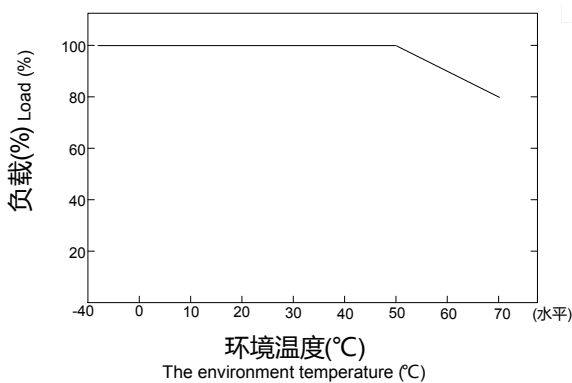

静态特性曲线 The static characteristic curve

