



三一精工

EPS 开关电源 EPS Switching Power Supply

EPS-SP-4303

■ 特性

■ Characteristic



- 国际通用全范围交流输入
- 内置 EMI 滤波器
- 具有过流及短路保护
- 充电过压、欠压保护
- 100%负载老化
- LED 电源指示灯
- 高效率，长寿命和高信赖度
- 可根据用户选型定制

- International Universal AC input/ Full range
- Built-in EMI filter
- Short circuit/Over load Protections
- Charging overvoltage and undervoltage protection
- 100% full load burn-in test
- LED indicator for power
- High efficiency, long life and high reliability
- Can be customized according to user selection

电气规格 SPECIFICATOIN

型号 MODEL		4303-12		4303-24	
		CH1	CH2	CH1	CH2
输出 Output	直流电压 DC Voltage	13.5V	13.5V	27V	27V
	额定电流 Rated Current	3A	/	1.5A	/
	电流范围 Current Range	0~3A	/	0~1.5A	/
	充电电压 Charging Voltage	/	13.5V	/	27V
	充电电流 Charge Current	/	0~0.8A	/	0~0.8A
	额定功率 Rated Power	40.5W	/	40.5W	/
	波纹与噪声最大(备注2) Ripple & Noise Max. (Note2)	120mVp-p	/	120mVp-p	/
	电压调整范围 Voltage Adj. Range	±10%	/	±10%	/
	电压精度(备注3) Voltage Tolerance (Note 3)	±5%	/	±5%	/
	线性调整率(备注4) Line Regulation (Note 4)	±0.5%	/	±0.5%	/
	负载调整率(备注5) Load Regulation (Note 5)	±1.0%	/	±1.0%	/
	启动、上升时间 Setup、Rise Time	500ms, 50ms/220Vac (满载时 Full load)			
保持时间(Typ.) Hold up time (Typ.)	50ms/220Vac (满载时 Full load)				
输入 Input	电压范围 Voltage Range	100~240Vac			
	频率范围 Frequency Range	50/60Hz			
	效率(Typ.) Efficiency (Typ.)	82%			
	交流电流(Typ.) Ac Current (Typ.)	0.8A/220Vac			
	浪涌电流(Typ.) Inrush Current (Typ.)	40A			
漏电流(Typ.) Leakage Current (Typ.)	3.5mA				
保护 Protection	过载保护 Over Load protection	105%~150% 保护模式: 打嗝模式, 负载异常条件移除后可自动恢复 Protection type: Hiccup mode, recovers automatically after fault condition is removed			
	低压保护 Over Voltage protection	78%~90% 保护模式: 打嗝模式, 低压异常条件移除后可自动恢复 Protection type: Hiccup mode, recovers automatically after fault condition is removed			
	过充保护 Over Shoot protection	保护模式: 器件截至模式, 过充异常条件移除后可自动恢复 Protection mode: the device up mode, after removing the abnormal conditions can be automatically restored			
功能 Features	功能介绍 Features Introduction	对电池长期在线浮充, 充电效率高, 电池饱和度可高达 90%以上 Battery floating long-line, high charging efficiency, battery saturation can be up to 90%			
		充满自停, 防止电池过充, 有效延长电池的使用寿命 Stopped to prevent overcharging, effectively extending the battery life			
		市电/电池自动切换, 切换时间极短, 无需人员值守 Mains / battery automatic switchover time is very short, without staff on duty			
		可直接用电池启动 EPS, 满足用户的应急需求 Can directly start the EPS batteries to meet emergency needs of users			
环境 Environment	工作温度 Working Temp	-10℃~60℃			
	工作湿度 Working Humidity	20~90RH, 无冷凝 non-condensing			
	储存温度、湿度 Storage Temp、Humidity	-20℃~75℃ 10~98RH, 无冷凝 non-condensing			
	温度系数 Temp. Coefficient	±0.03%/℃ (0~50℃)			
	耐振荡 Vibration	10~500Hz, 5G 10 分钟/周期, X、Y、Z 轴各 60 分钟 10Min/1 cycle, period for 60min,each along X,Y,Z axes			
安规和电磁兼容 (备注7) Safety & EMC (Note 7)	安全规范(备注6) Safety Standards (Note 6)	GB4943, EN60950			
耐压 Withstand Voltage	I/P-O/P:2.5KVAC I/P-FG:1.5KVAC O/P-SFG:1.5KVAC				
绝缘阻抗 Isolation Resistance	I/P-O/P I/P-FG O/P-FG:100M Ohms/500VDC/25℃/70%RH				
电磁兼容发射 EMI Conduction Radiation	符合 Compliance to :EN55022, EN61000-3-2, 3, FCC part15, GB9254 class B, GB17625.1				
电磁兼容抗扰度 EMS Immunity	符合 Compliance to :EN61000-4-2, 3, 4, 5, 6, 8, 11, A 级轻工行业标准 light industry level, criteria A				
其它 Others	MBTF	≥100000h.			
	尺寸 Dimension/包装 Packing	110*78*38m(L*W*H) /0.25KG;100pcs/25Kg			
备注 Note	<p>1. 如未特别说明, 所有规格参数均在输入为 230VAC、额定负载、25℃环境温度下进行测量。 All parameters NOT specially mentioned are measured at 230VAC input, rated load and 25℃ of ambient temperature.</p> <p>2. 波纹和噪声测量方法: 使用一条 12" 双绞线, 同时终端要并联 0.1uF 和 47uF 的电容, 在 20MHZ 带宽下进行量测。 Ripple & noise are measured at 20MHz of bandwidth by using a 12" twisted pair-wire terminated with a 0.1uf & 47uf parallel capacitor.</p> <p>3. 精度: 包含设定误差, 线性调整率和负载调整率。 Tolerance: includes set up tolerance, line regulation and load regulation.</p> <p>4. 线性调整率测量方法: 在额定负载下, 从低电压到高电压测试。 Line regulation is measured from low line to high line at rated load.</p> <p>5. 负载调整率测量方法: 从 0% 到 100% 额定负载。 Load regulation measurement: from 0% to rated load of 100%</p> <p>6. 按照 GB4943.1 的要求, 电源仅适用于海拔 2000 米以下地区和非热带气候条件下安全使用。 In accordance with the requirements of GB4943.1 power applies only to an altitude of 2000 meters in the following areas and non-tropical climate conditions for Safe use.</p> <p>7. 电源被视为系统内元件的一部分, 需结合终端设备进行电磁兼容相关确认。 The power supply is considered part of the system components, to be with terminal equipment related to electromagnetic compatibility Relevant confirmation..</p>				



尺寸 Size

单位: mm

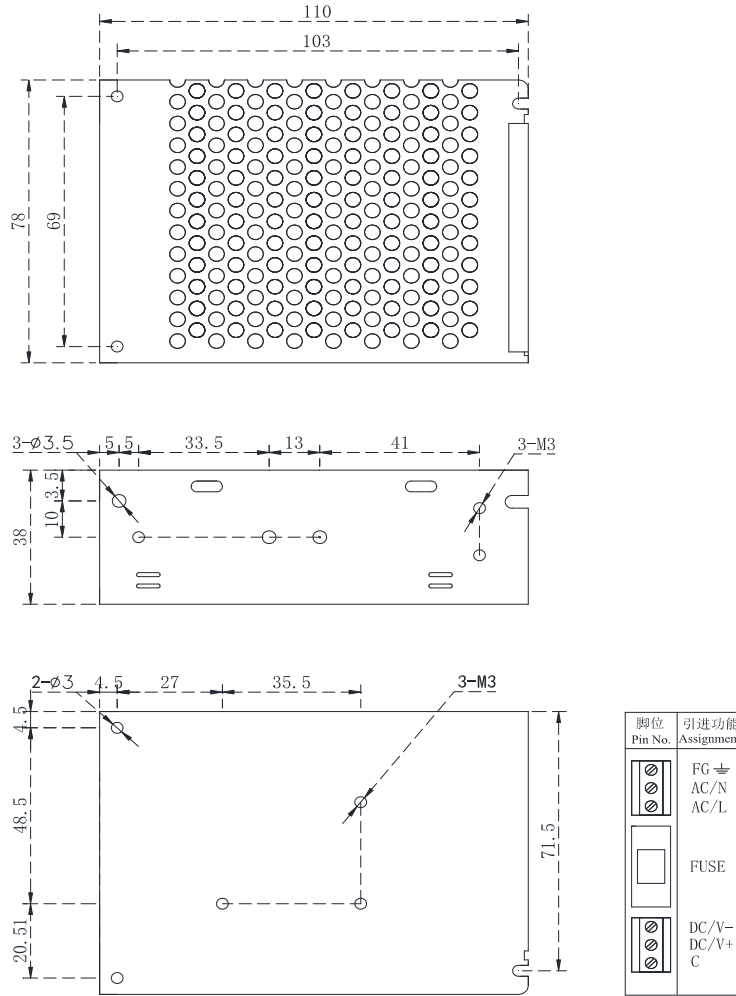

方框图

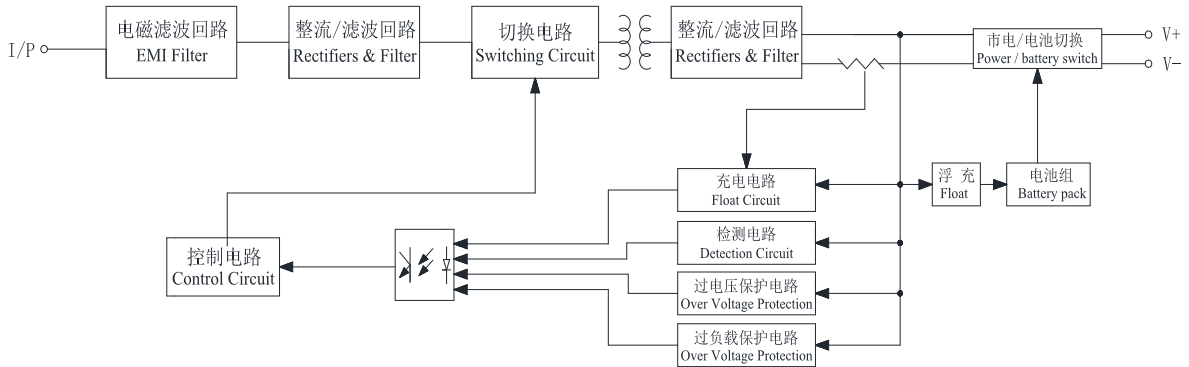

减额曲线 Derating Curve

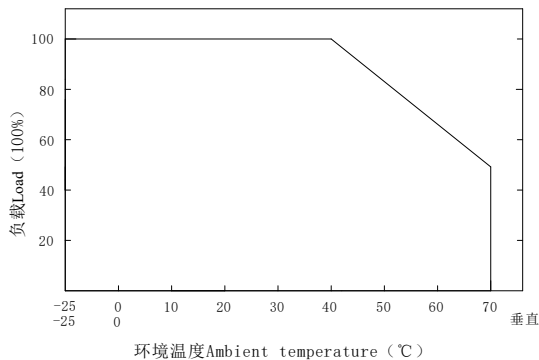

静态特性曲线 Static Characteristics

